

Mounting orientation
Sens de montage
Sentido de montaje

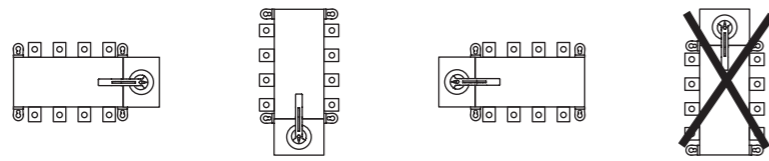

Mounting of terminal covers
Montage des capots
Montaje de los Cubrebornes

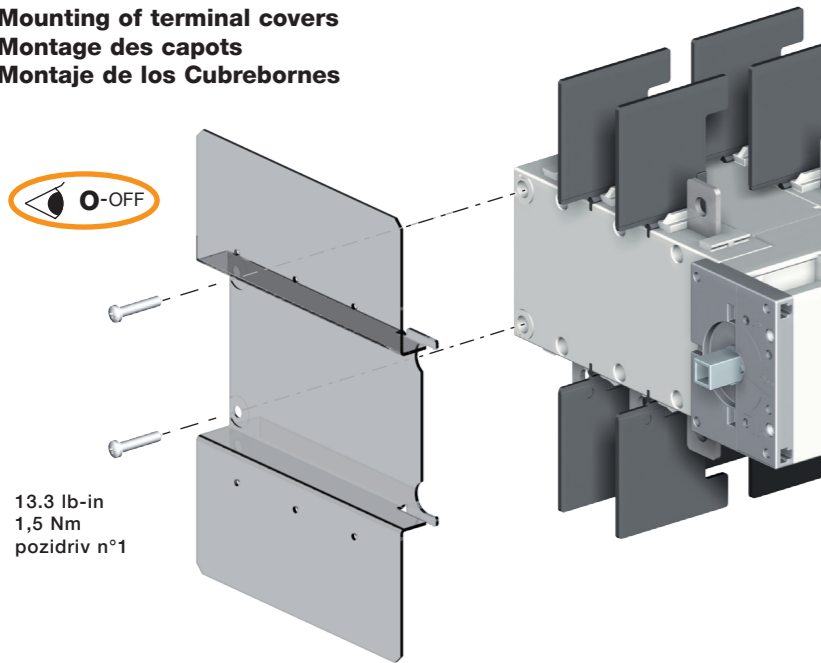

13.3 lb-in
1,5 Nm
pozidriv n°1

Terminal cover
Ecrans
Cubrebornes

USED FOR
UTILISE POUR
UTILIZADO PARA

41583021 → ① 41502012 / 41502022
41584021 → ② 41504012 / 41504022

Mounting of auxiliary contacts
Montage des contacts auxiliaires
Montaje de los contactos auxiliares

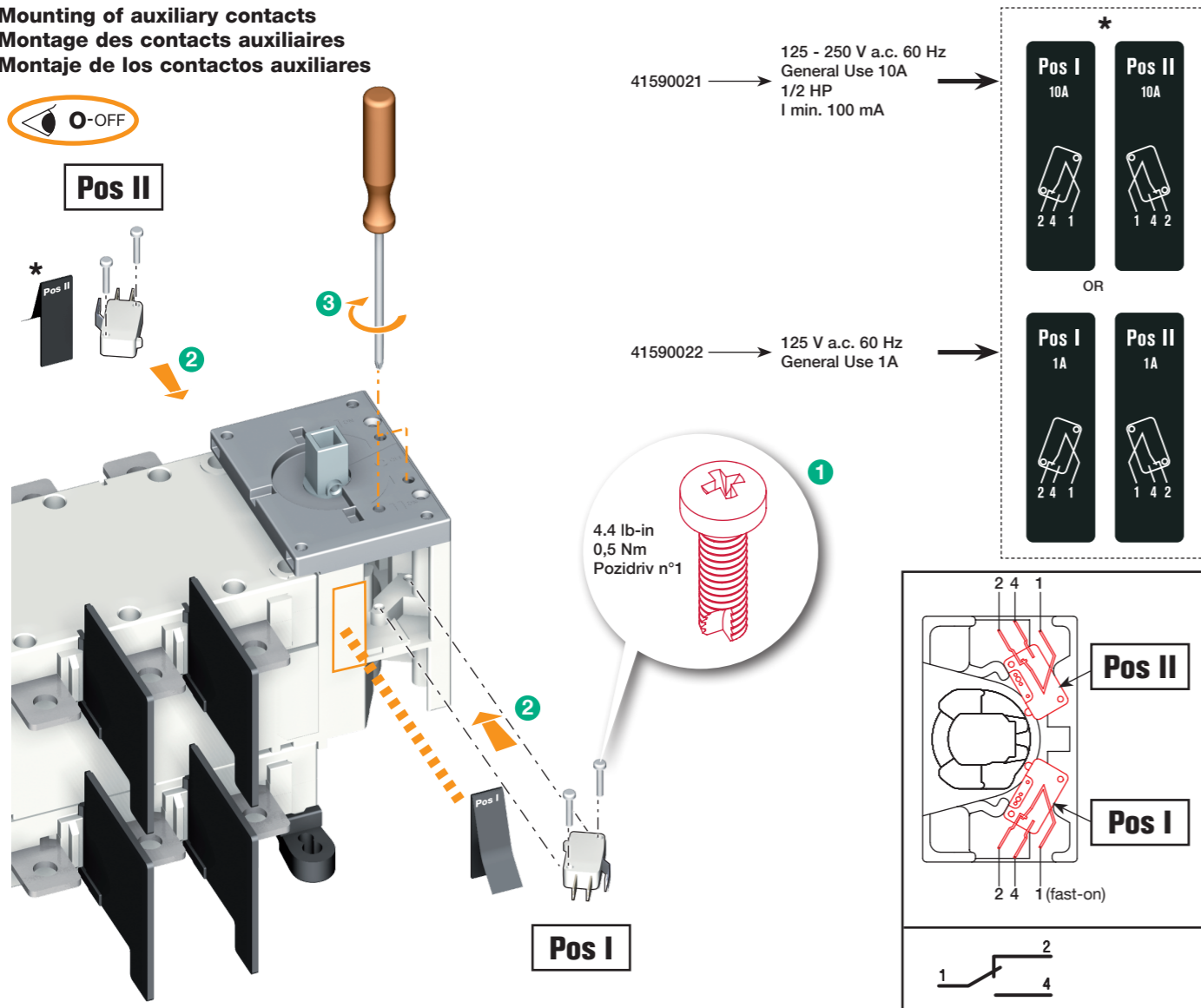

41590021 → 125 - 250 V a.c. 60 Hz
General Use 10A
1/2 HP
I min. 100 mA

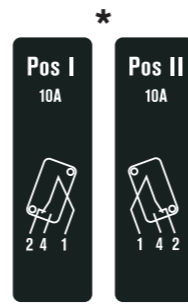

OR

41590022 → 125 V a.c. 60 Hz
General Use 1A

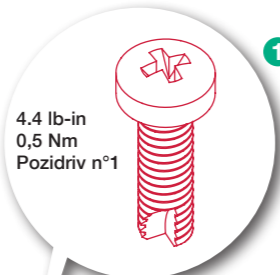
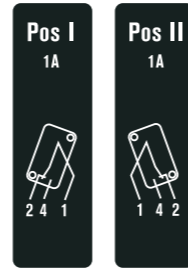

4.4 lb-in
0,5 Nm
Pozidriv n°1

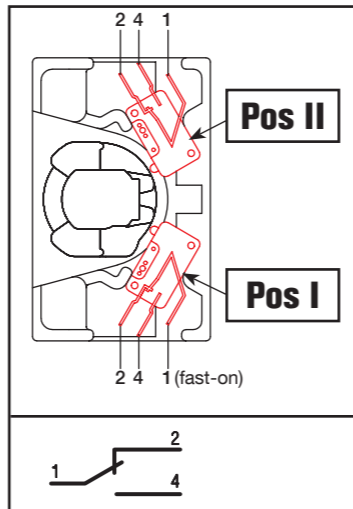

⚠ DANGER / DANGER / PELIGRO

HAZARDOUS VOLTAGE

- This equipment must be installed and serviced only by qualified electrical personnel.
- Turn off all power supplying this equipment before working on or inside equipment.
- Always use a properly rated voltage sensing device to confirm power is off.
- Replace all devices, doors, and covers before turning on power to this equipment.
- Maintain electrical clearances between cable and live parts.

Failure to follow these instructions will result in death or serious injury.

TENSION DANGEREUSE

- L'installation et l'entretien de cet appareil ne doivent être effectués que par du personnel qualifié.
- Coupez l'alimentation de cet appareil avant d'y travailler.
- Utilisez toujours un dispositif de détection de tension à valeur nominale approprié pour confirmer que toute alimentation est coupée.
- Remplacez tous les dispositifs, les portes et les couvercles avant de mettre cet appareil sous tension.
- Maintenez les distances d'isolement électrique entre le câble et les pièces sous tension.

Si ces précautions ne sont pas respectées, cela entraînera la mort ou des blessures graves

TENSION PELIGROSA

- Solamente el personal de mantenimiento eléctrico especializado deberá instalar y prestar servicios de mantenimiento a este equipo.
- Desenergice el equipo antes de realizar cualquier trabajo en él.
- Siempre utilice un dispositivo detector de tensión adecuado para confirmar la desenergización del equipo.
- Vuelva a colocar todos los dispositivos, las puertas y las cubiertas antes de energizar este equipo.
- Mantenga un espacio adecuado para la instalación eléctrica entre el cable y las piezas energizadas.

El incumplimiento de estas precauciones podrá causar la muerte o lesiones serias.

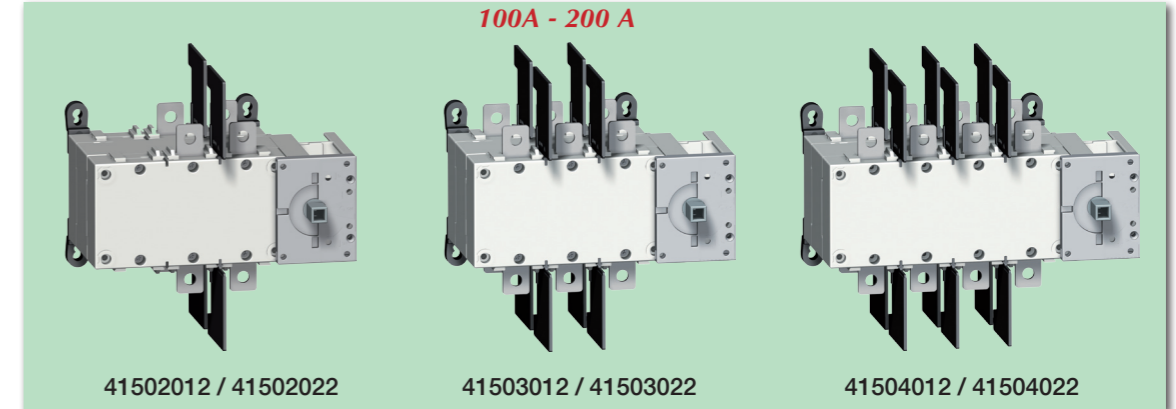

41502012 / 41502022

41503012 / 41503022

41504012 / 41504022

Switch and accessories
L'interrupteur et ses accessoires
El interruptor y sus accesorios

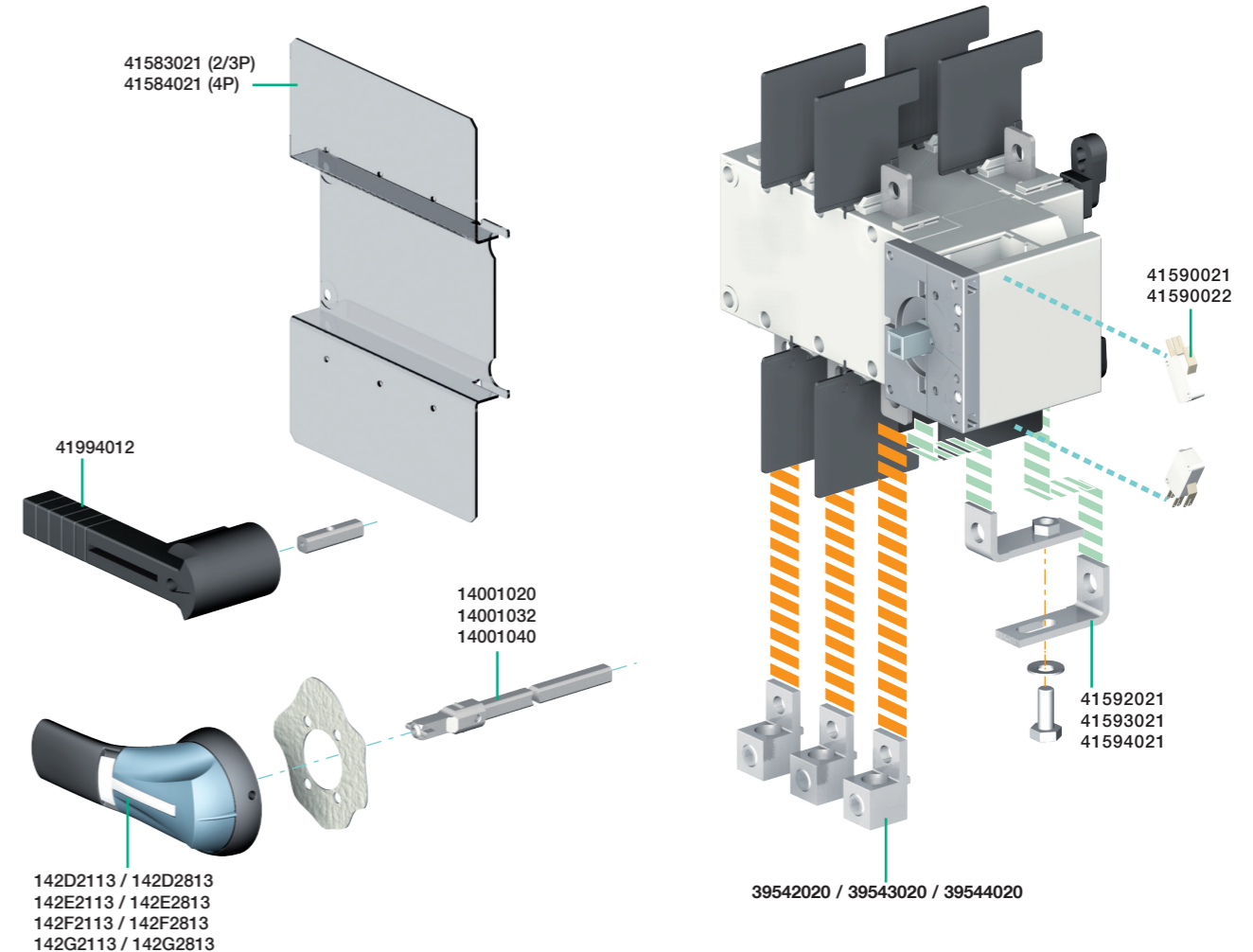

41583021 (2/3P)
41584021 (4P)

41994012

14001020
14001032
14001040

142D2113 / 142D2813
142E2113 / 142E2813
142F2113 / 142F2813
142G2113 / 142G2813

39542020 / 39543020 / 39544020

41590021
41590022

41592021
41593021
41594021

- ① 41502012 / 41502022
- 41503012 / 41503022
- ② 41504012 / 41504022

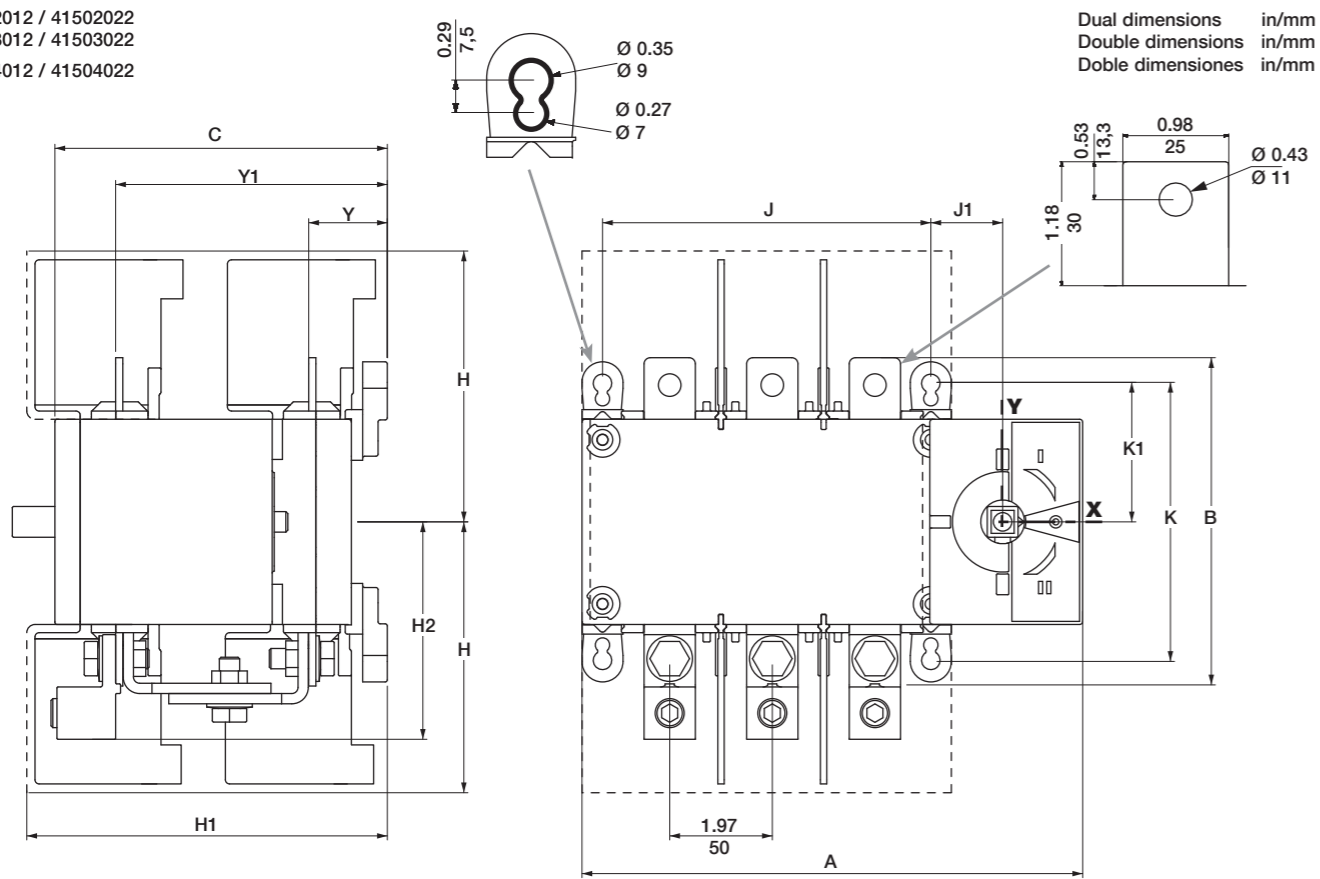

Dual dimensions in/mm
 Double dimensions in/mm
 Doble dimensiones in/mm

	A		B		C		H		H1		H2		J		J1		K		K1		Y		Y1	
	in	mm	in	mm	in	mm	in	mm	in	mm	in	mm	in	mm	in	mm	in	mm	in	mm	in	mm	in	mm
① 2/3P	9.60	244	6.30	160	6.37	162	5.08	129	6.93	176	4.21	107	6.30	160	1.37	35	5.31	135	2.65	67.5	1.51	38.5	5.21	132.5
② 4P	11.57	294											8.26	210										

Minimum enclosure dimensions
Dimensions minimum des coffrets
Dimensiones minimas de las cajas

- ① 41502012 / 41502022
- 41503012 / 41503022
- ② 41504012 / 41504022

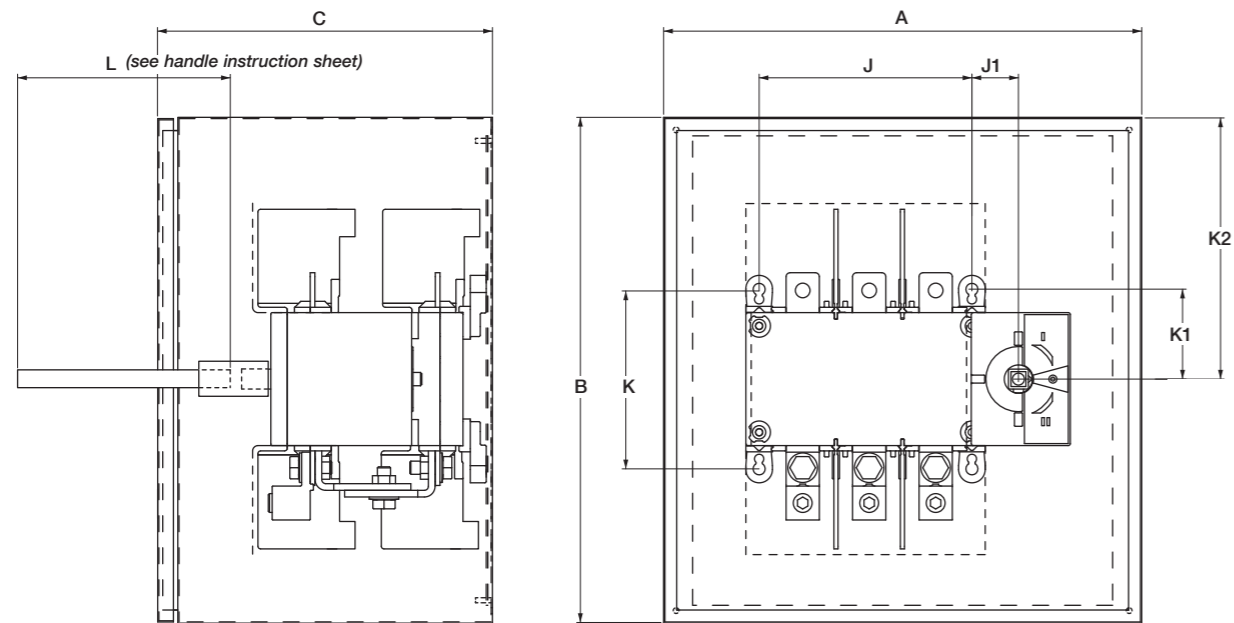

	A		B		C		J		J1		K		K1		K2	
	in	mm	in	mm	in	mm	in	mm	in	mm	in	mm	in	mm	in	mm
① 2/3P	18	457	18	457	10	254	6.30	160	1.37	35	5.31	135	2.67	68	12	305
② 4P							8.26	210								

Connection
Raccordement
Conexión

- Lugs*
Bornes à cage
Bornes
- USED FOR
 UTILISE POUR
 UTILIZADO PARA
- 39542020 x3 → 41502012 / 41502022
 - 39543020 x3 → 41503012 / 41503022
 - 39544020 x3 → 41504012 / 41504022

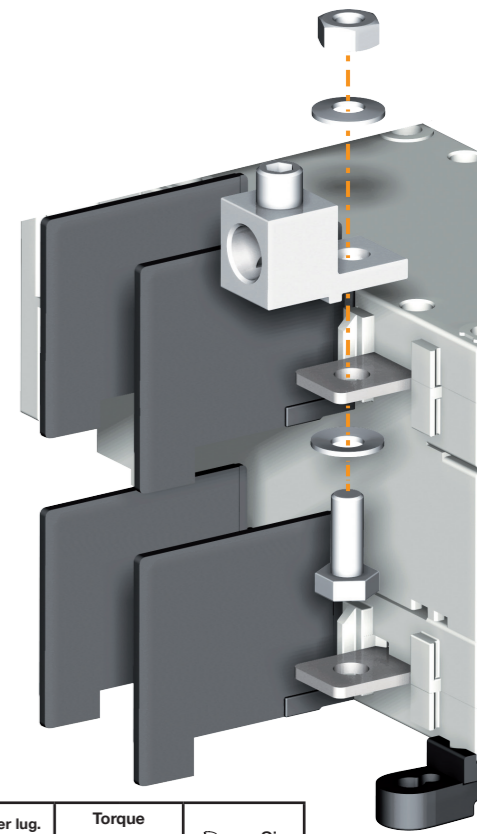

When ordering ensure to order QTY 3 of each lug reference
 (2 x for source 1 and source 2 incoming power cables + 1x for outgoing cables)

Ref. lugs Ref. bornes à cage Ref. bornes	Designation Désignation Designación	Quantity per reference. Quantité par ref. Cantidad por referencia	Size / Section Sección (AWG)		Openings per lug. Nombre de points de connexion. Numero de puntos de conexión.	Torque Couple Par de apriete		Size
			min.	max.		lb-in	Nm	
39542020	CMC LA300-R	2	# 6	300 Kcmil	1	160	18	13
39543020		3						
39544020		4						

- Bridging bars*
Barres de pontage
Pletina de puentado
- USED FOR
 UTILISE POUR
 UTILIZADO PARA
- 41592021 → 41502012 / 41502022
 - 41593021 → 41503012 / 41503022
 - 41594021 → 41504012 / 41504022

